

Prizelawn® BF_{IT}
TRACTOR DRAWN
COMMERCIAL BROADCAST SPREADER

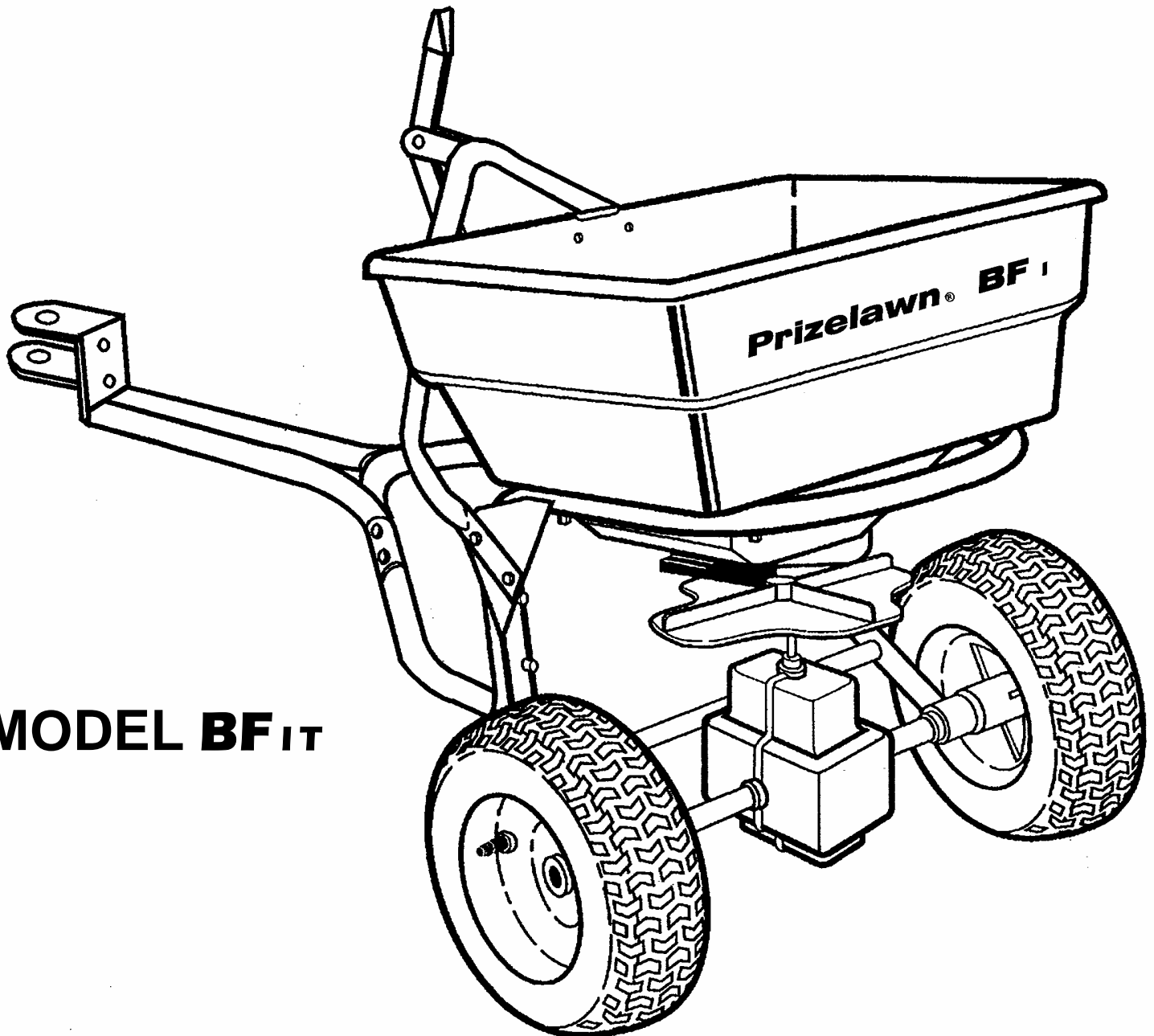

MODEL BF_{IT}

OWNER'S MANUAL

OPERATION

- 1** Remove spreader and components from carton and place spreader upside down. Attach hitch brace to the **outside of frame** using (4) 1/4-20 x 5/8" hex bolts, (4) lockwashers, and (4) nuts. Slide drive and free wheels on axle as shown with the longer portion of wheel hub facing the frame. Secure free wheel with a 5/32 Dia. x 1 1/4" cotter pin.

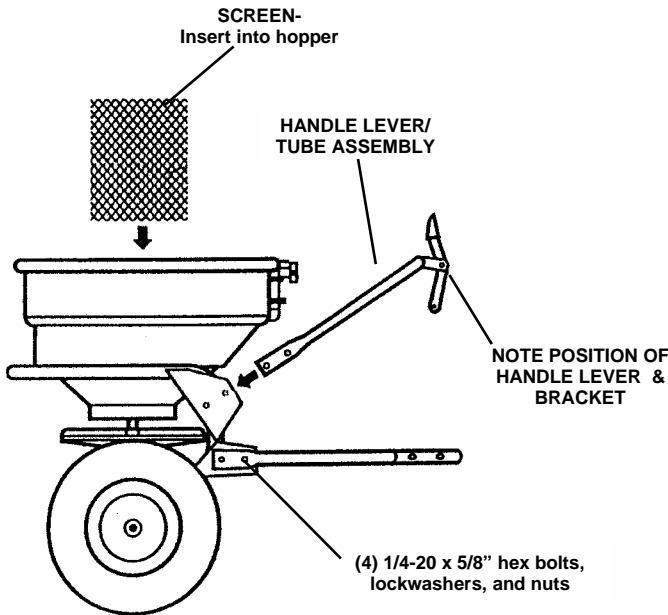
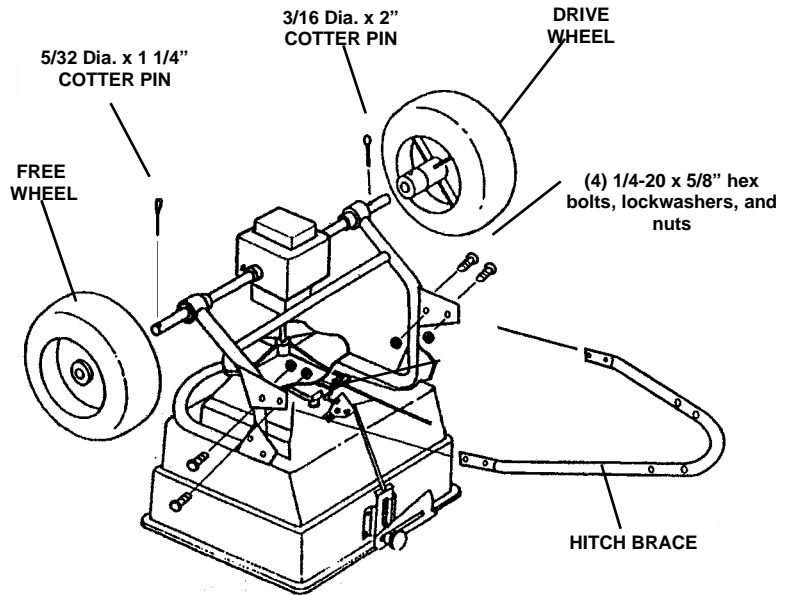

- 2** Turn spreader upright on wheels and insert screen into hopper. Attach handle lever /tube assembly to the outside of frame brackets making sure the handle lever and brackets point as shown. Secure with (4) 1/4-20 x 5/8" hex bolts, (4) lockwashers, and (4) hex nuts.

- 3** Install control tube to control lever using 1/4 Dia. clevis pin and 3/32" Dia. x 5/8" cotter pin. Remove tape holding the lower rod to the pivot lever and slide opposite end of control tube onto lower control rod. Secure with a 3/32 Dia. cotter pin. Attach trim control lever to bracket next to the handle lever as shown using (2) #10 x 1/2" screws and locknuts. Install hitch tube onto hitch brace with the hitch bracket facing as shown. Secure with (4) 1/4-20 x 1 1/2" hex bolts, (4) lockwashers, and (4) nuts.

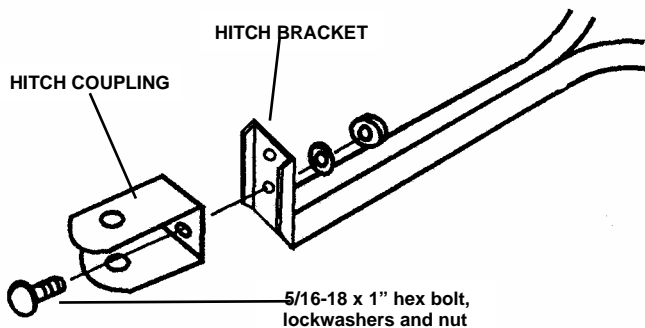
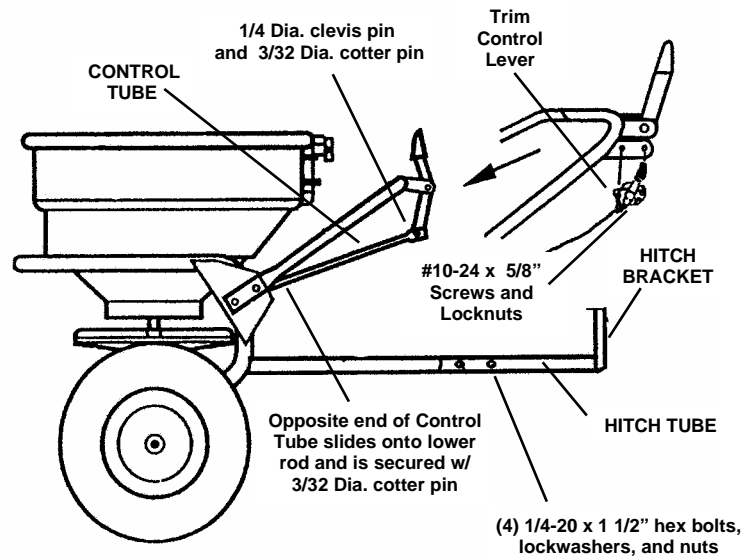

- 4** Attach hitch coupling to hitch bracket using a 5/16-18 x 1" hex bolt, lock washer, and nut. Bracket can be adjusted to best suit your tractors hitch height.

- 5** To check spreader for complete shutoff, pull the on/off control lever back to the "OFF" position. Determine if the port holes are completely closed. If they are not, loosen the handle lever/ tube assembly bolts and push down on the assembly and the front of spreader. Re-tighten bolts and check shutoff.

OPERATION

1 Check the product package for the rate setting (letter), pattern setting (number), and recommended swath width. Loosen the rate control knob and slide the rate plate to the proper setting. The pattern controls are adjusted by setting either the trim control plate or the right auxiliary shut-off slide mounted on the shut-off plate. The trim control is remotely operated at the handle, while the auxiliary slide is set at the hopper. See **"PATTERN ADJUSTMENT"** for further details.

2 Before filling hopper, make sure on/off lever is in the "OFF" position. Make sure screen is in the hopper. Fill hopper.

3 Start spreader moving before opening ports, close ports before stopping spreader. Always pull spreader, **DO NOT PUSH**.

4 Adjust hitch coupling to assure spreader is level. Tipping spreader too far can cause uneven spreading.

5 The settings and swath width on the product label are recommended starting points. Always check the delivery rate and pattern on a small area before treating a large area. Actual delivery rates can vary due to weather conditions, operating variables, and condition of the products being applied. See **"HOW TO DETERMINE SPREADER SETTING AND SWATH WIDTH"** FOR DETAILS.

6 Pull spreader at 2 1/2 m.p.h. (18 feet in 5 seconds). Apply header strips at each end of area to be treated then space trips across the area as shown.

7 To keep material off walks, flower beds, borders, etc., the pattern can be narrowed by pulling the trim control lever mounted on the handle to the "ON" position. The pattern will end just beyond the right wheel.

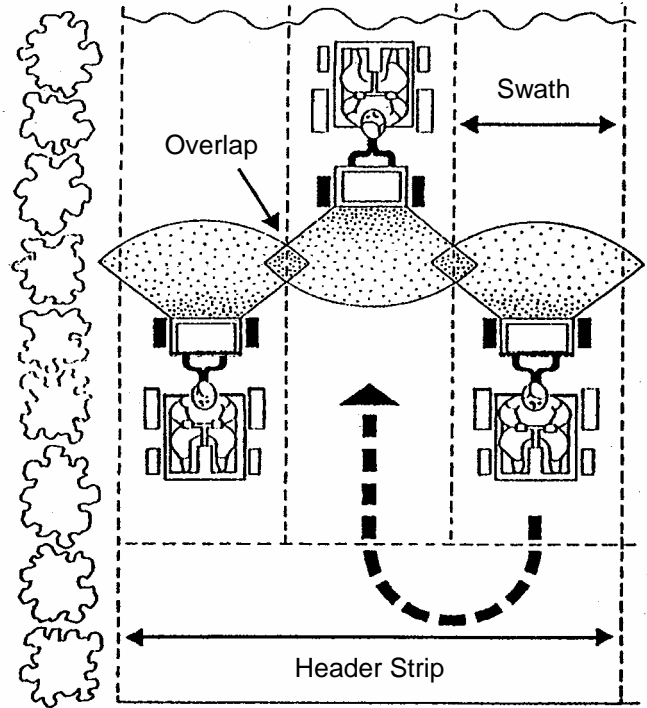

9 Ice melt products can be applied using a normal width, or a narrow band can be applied by closing the trim control and the auxiliary shut-off slide, leaving only the center port open as shown.

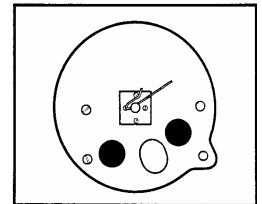

10 Empty spreader after each use. Return leftover material to its original container.

PATTERN ADJUSTMENT

Normal spreading of material requires no adjustment unless otherwise stated on the package. In those cases where the spread pattern has shifted, the pattern can be adjusted. If the pattern is heavier to the left (as viewed from the operating position), loosen the knob and move the control plate in toward the hopper. If it is heavy to the right, move the control plate out away from the hopper. Tighten knob after each adjustment is made. A scale is stamped into the control plate to provide settings.

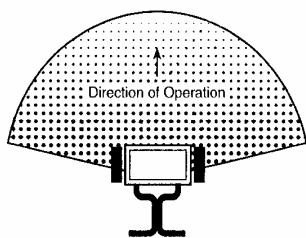

Normal Pattern

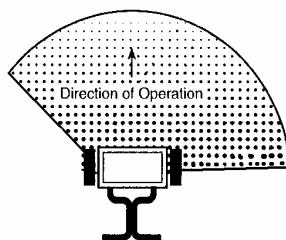

Pattern Heavy Right

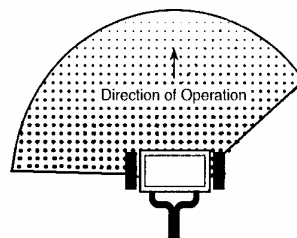

Pattern Heavy Left

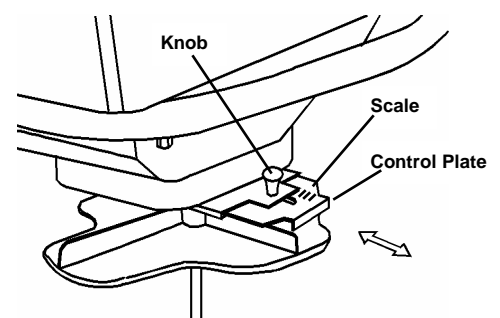

HOW TO DETERMINE SPREADER SETTINGS AND SPREAD WIDTH

Two major factors should be considered when determining correct spreader settings of any product:

1. The product application rate, or the amount of material applied per 1,000 square feet.
2. The effective pattern width, or the actual width in which material is applied. Label settings are a guide and can be affected by numerous factors

EFFECTIVE PATTERN WIDTH

A simple visual pattern test can be made by operating spreader over a non-turf area and evaluating the pattern. A more accurate method is to place a row of common, disposable, aluminum cake pans approximately 1 foot on centers. Set the rate plate at a middle setting and make 3 or 4 passes in the same direction as shown. Pour the material collected from each pan into individual bottles of the same size. Set them side by side in order, and visually inspect their volume. If the pattern is not centered (example: volume in bottle #2 left not equal to bottle #2 right) adjust the pattern control as described in the "PATTERN ADJUSTMENT" section.

Once the pattern is uniform, the effective pattern width can be determined. The effective pattern

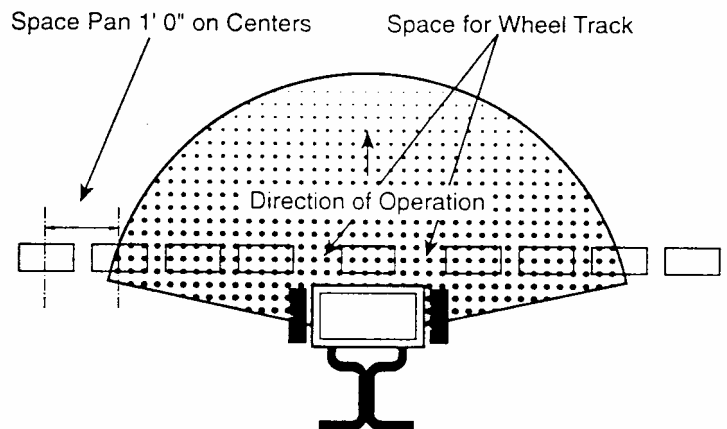

width is the distance out from the spreader to a point where the amount of material is 1/2 the average amount in the center pans. This distance is multiplied by 2 to achieve the total effective pattern width.

APPLICATION RATE

Knowing the effective pattern width (for example, 10 feet), measure a distance equal to 100 square feet (10' x 10' swath width). Determine the product coverage in pounds / 100 sq. ft. by taking the weight of product and dividing it by the recommended square foot coverage (add two zeroes to the weight of the bag).

EXAMPLE: Product Weight: 25 lbs.
Sq. Ft. Coverage: 5000 sq. ft.
 $2500 \text{ lbs.} \div 5000 \text{ sq. ft.}$
 $= .5 \text{ lbs.} / 100 \text{ sq. ft.}$

Weigh out between 15 to 20 lbs. of material and spread over the 100 sq. ft. area. Weigh remaining material left in hopper and adjust rate setting as required. Repeat test until application rate is correct.

MAINTENANCE

- 1** Never store material in spreader. Return unused product to its original container.
- 2** Wash spreader thoroughly after each use and dry completely in the sun or heated area.
- 3** Grease the axle bearings on the frame. Oil the impeller shaft bearing in hopper, and pivot points on the shut-off linkage and the spring in the housing behind the rate plate as shown.
- 4** Remove the gear cover and wash gears thoroughly and oil all bearing areas as shown. Re-install gear cover.
- 5** Gear mesh should be checked on a regular basis during high use periods. Clearance between the axle gear and pinion gear should be minimal but not tight. If adjustment is necessary, loosen axle collar set screw and hold gears together. Slide axle collar against gear support and tighten axle collar set screw. Spin drive wheel. Gears should run freely and smoothly.
- 6** Impeller surface should be cleaned periodically to remove build-up of product. Build-up can cause the spread pattern to change.
- 7** Tire pressure should be 20-25 PSI.

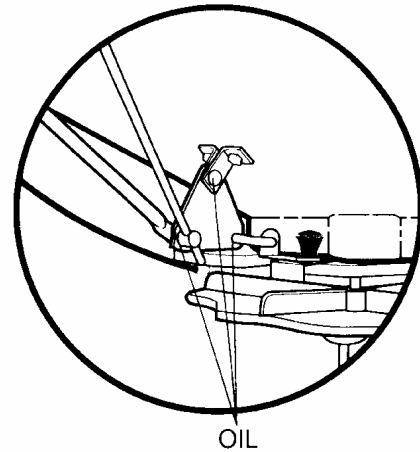
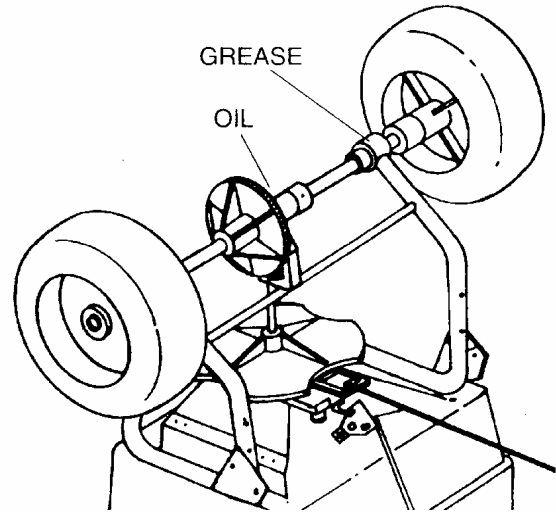

CALIBRATION INSTRUCTIONS

The **BF1T** spreader was factory calibrated, however, calibration should be checked occasionally to assure optimum performance.

- 1** Pull the on/off lever to the closed position. Set the rate control plate at setting "A".
- 2** Flip on/off lever forward to the "ON" position. Check the center port hole. It should be just open as shown. If adjustment is necessary continue to step #3.
- 3** Remove cotter pin from adjusting swivel and slide off control tube. Slide swivel out of hole in pivot bracket (NOTE SIDE OF PIVOT BRACKET FROM WHICH IT WAS REMOVED). Thread swivel up or down on lower rod as required. Install swivel back onto pivot bracket facing the same way it was removed. Check calibration. Repeat procedure until calibration is correct. Reinstall control tube and cotter pin.

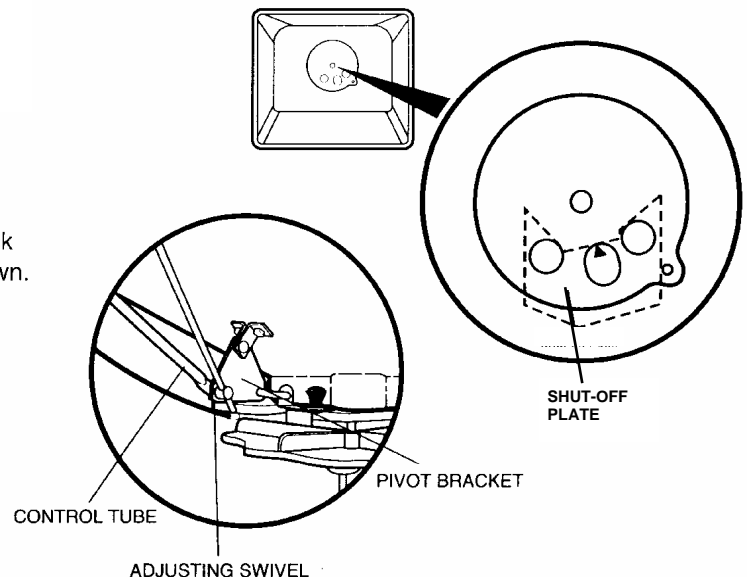





RATE SETTING CONVERSION

The following provides approximate **Prizelawn BFI** settings for those units listed.

BFI/ BFI Setting	A	B	C	D	E	F	G	H	I	J	K	L	M	N	O	P	Q	R	S	T	U	V	W	X	Y	Z
Lesco #029600 Setting	A	—	B	C	D	—	E	F	—	G	H	I	—	J	K	L	—	M	N	O	—	P	Q	R	—	S
Scotts R8A/SR-1 Setting	C	D	E	F	G	H	I	J	K	L	M	N	O	P	Q	R	S	T	U	—	V	W	—	X	Y	Z
Earthway 2200/2400 Setting	5	—	—	—	—	10	—	—	—	—	15	—	—	—	—	20	—	—	—	—	25	—	—	—	—	30
Spyker 76/78-2 Setting	—	—	3	—	—	—	4	—	—	5	—	—	6	—	—	7	—	—	8	—	—	—	9	—	—	10

The following provides approximate **Prizelawn BFI** settings when only the product weight, square foot coverage, and visual inspection of material is available.

FERTILIZER PARTICLE SIZE		BAG RATE Pounds of fertilizer used per 1,000 sq. ft. of coverage	APPROX. SETTING	SPREAD WIDTH (IN FEET)
Large, heavy particles		5	J	12
		10	K	12
		15	L	12
Medium- mixed particles		5	G	10
		10	H	10
		15	I	10
Small particles (nitrogen)		1	D	10
		2	F	10
		3	J	10
Mixed size particles -some fines		5	I	8
		10	J	8
		15	K	8
Light weight particles		5	F	6
		10	G	To
		15	H	8

The conversions should be used as guidelines for establishing proper rate settings for the particular product being applied. Steps for obtaining the most accurate settings are outlined in the "How to Determine Spreader Settings and Spread Width" section of this manual.

These settings are approximate and may vary due to physical characteristics of the product. Walking speed, wear, condition of the turf and humidity, may cause actual rate setting to deviate. No expressed nor implied warranty or guarantee is provided as to coverage or uniformity indicated by these rate settings.

Parts List for Model BFI T

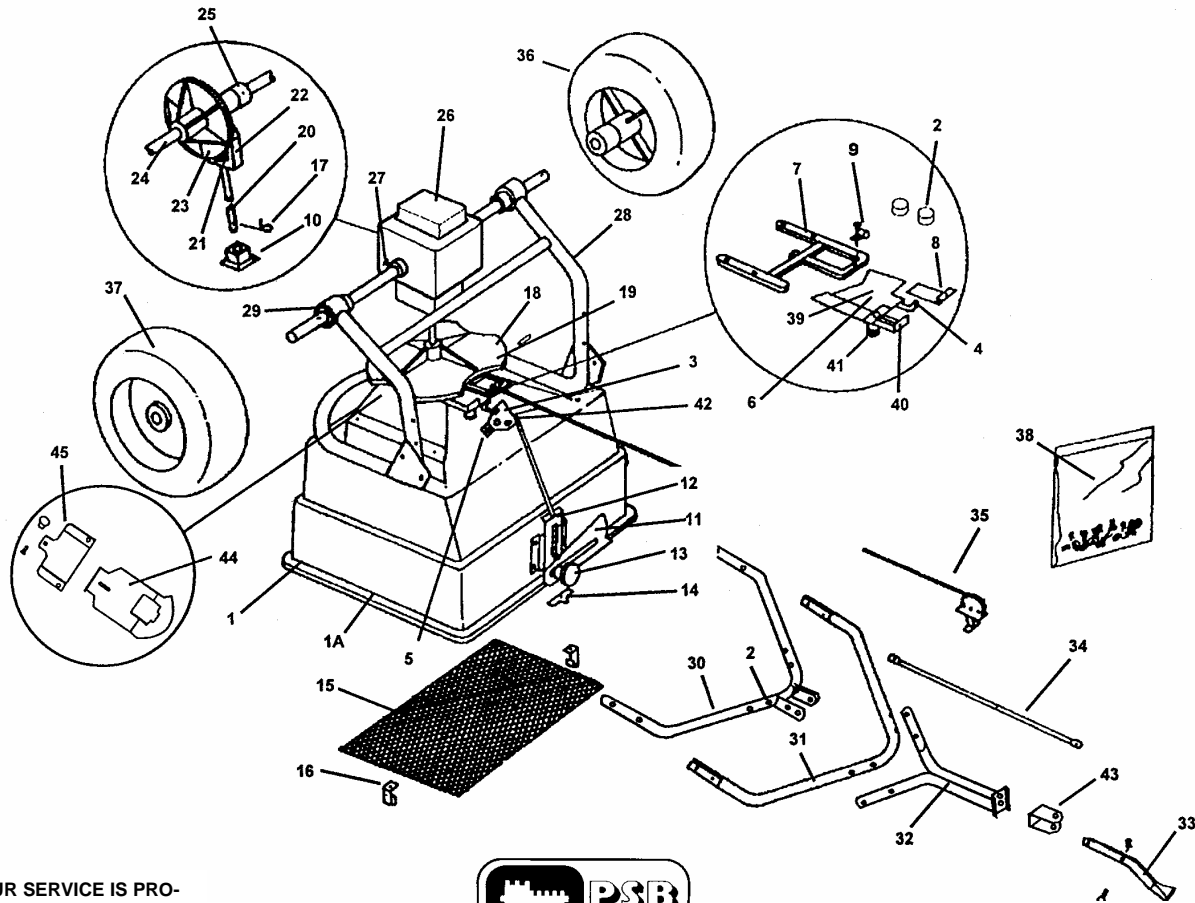

PART OF OUR SERVICE IS PROVIDING REPLACEMENT PARTS, Parts may be obtained through your local distributor. Be sure to give the:

1. SPREADER MODEL NUMBER
2. SPREADER NAME
3. PART NUMBER
4. NAME OF PART AS SHOWN

IF YOUR LOCAL DISTRIBUTOR CANNOT SUPPLY PARTS, CONTACT:



PSB Company
 555 West Goodale Street
 P.O. Box 1089
 Columbus, Ohio 43216-1089
 (614) 228-5781 EXT. 655

#	BFI T	DESCRIPTION	#	BFI T	DESCRIPTION	#	BFI T	DESCRIPTION
1	14815-1	Hopper*	16	14864	Screen Clip (2)	31	14824-1	Hitch Brace
1A	14877-1	Hopper Assembly	17	14865	Agitator	32	14996	Hitch Tube Assembly
2	14879	Hopper Hole Plug (2)*	18	14866-2	Impeller Assembly	33	12711-2	Handle Lever
3	14878	Pivot Lever Assembly*	19	14625	Impeller w/ Roll Pin**	34	14991	Control Tube
4	14846	Shut-Off Plate Link*	20	14867-3	Impeller Shaft**	35	14298	On/Off Control w/ Clamp
5	14848	Reinforcing Plate*	21	14833	Pinion Gear w/ Roll Pin**	36	14856	Drive Wheel w/ Cotter Pin
6	14840	Shut-Off Plate Assembly*	22	14834	Gear Support**	37	14857	Free Wheel w/ Cotter Pin
7	14836	Shut-Off Plate Guide*	23	14832	Axle Gear w/ Roll Pin	38	14998-1	Fastener Package
8	14847	Aux. Shut-Off Plate-LH.	24	14860	Axle	39	14838	Shut-Off Plate***
9	90060	Wire Clamp	25	14971	Axle Collar (3)	40	14839-1	Aux. Shut-Off Plate-RH***
10	14312-1	Impeller Bearing Ass'y*	26	14837	Gear Cover (2)	41	14001	Knob w/ Carriage Bolt***
11	14861	Rate Control Plate*	27	14868	Gear Cover Clamps (3)	42	14913	Adjusting Swivel
12	14885-1	Spring Housing	28	14988	Frame Ass'y. w/ Bearings	43	12895	Hitch Coupling
13	12704	Rate Knob w/ Washer*	29	14855	Axle Bearings (4)	44	14985	Pattern Control Plate
14	12708	Pointer W/ Screw & Nut*	30	14990-1	Handle Lever/ tube Ass'y	45	14884	Pattern Control Guide
15	14863	Hopper Screen						

*Parts in hopper ass'y, **Parts in impeller ass'y, *** Parts in shut-off plate ass'y

OPTIONAL ACCESSORIES

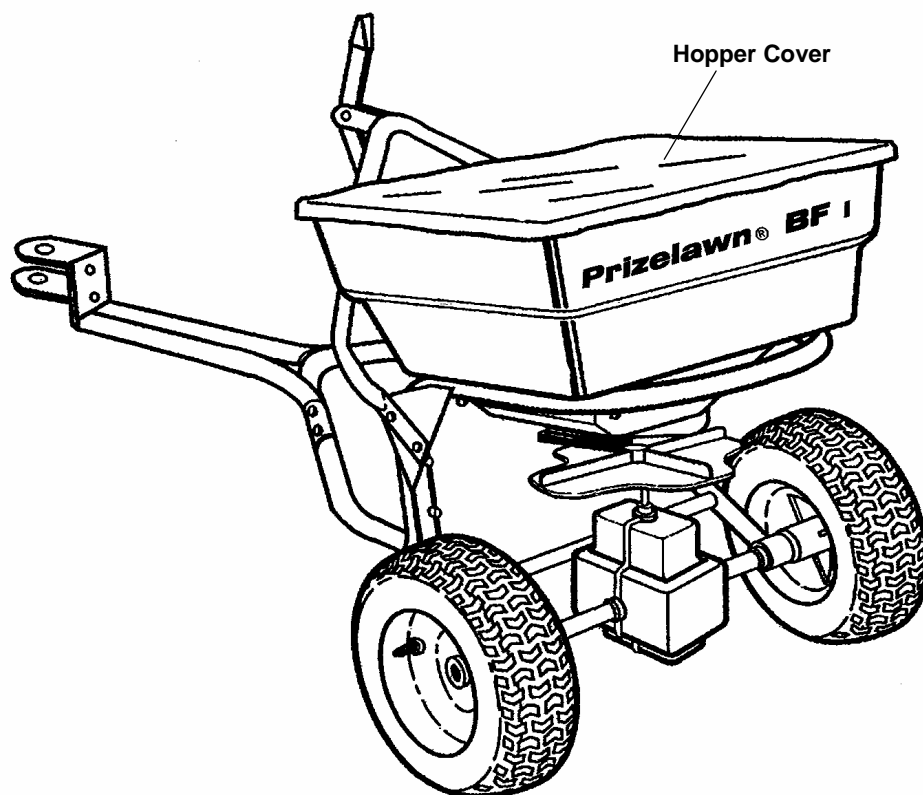

#14872 Hopper Cover

PART OF OUR SERVICE IS PROVIDING REPLACEMENT PARTS. Parts may be Obtained through you local distributor. Be sure to give the:

1. SPREADER MODEL NUMBER
2. SPREADER NAME
3. PART NUMBER
4. NAME OF PART SHOWN

IF YOUR LOCAL DISTRIBUTOR CANNOT SUPPLY PARTS OR ACCESSORIES, PLEASE CONTACT:

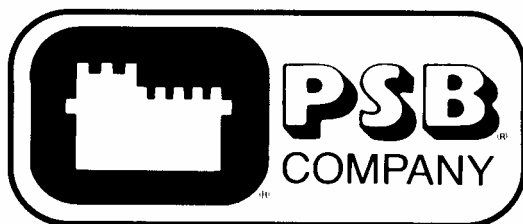

PSB Company
555 West Goodale Street
P.O. Box 1089
Columbus, Ohio 43216-1089
(614) 228-5781 EXT. 2655

Manufacturers of millions of quality lawn spreaders since 1946