

# PrizeLAWN<sup>®</sup> COMMERCIAL BROADCAST SPREADER

**MODEL *MPR I***

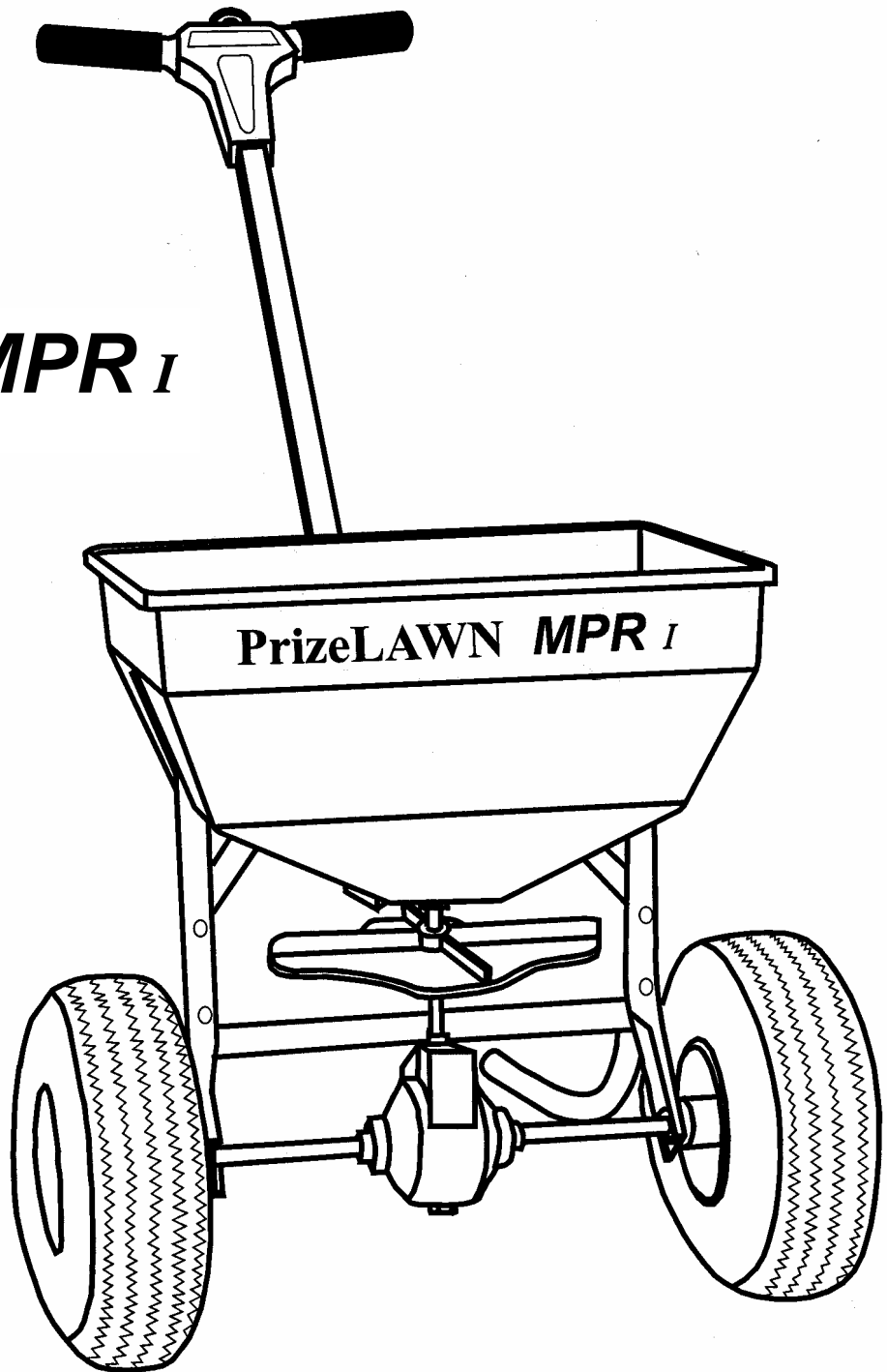

**OWNER'S MANUAL**

# ASSEMBLY

**1. Remove components from carton and place spreader upside down on a padded surface. Install LH. & RH. handle braces to frame as shown using four (4) 1/4-20 x 2 1/4" hex bolts and nuts but do not tighten.**

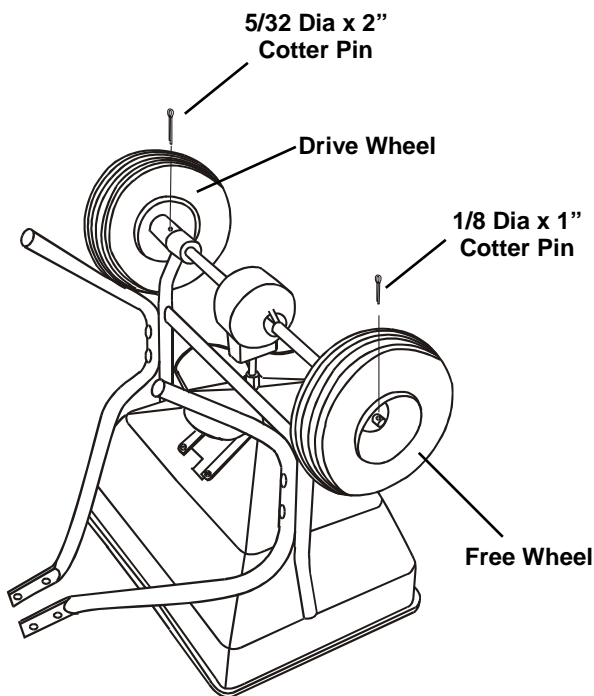
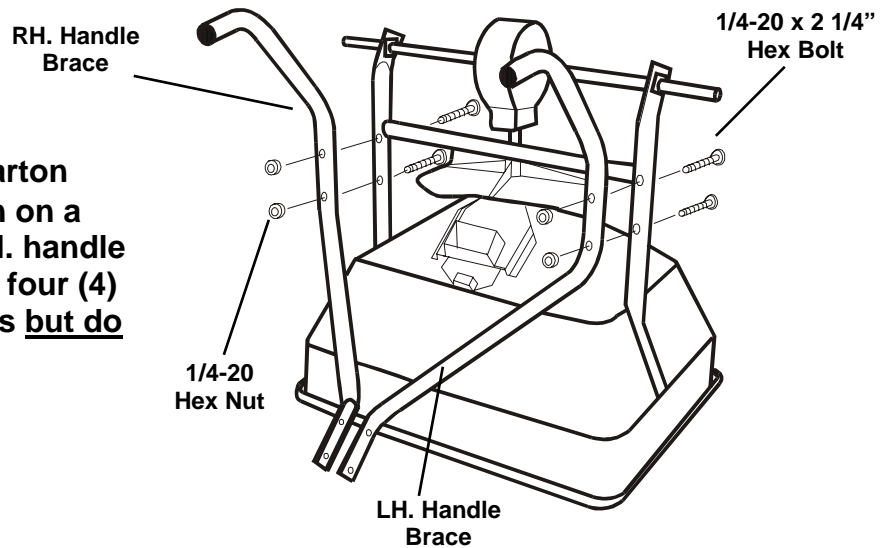

**2. Install drive wheel onto right-hand end of axle (you can identify the drive wheel by the cotter pin hole drilled in the hub). Hub must face toward frame. Align the hole in the drive wheel hub and the hole in the axle. Secure drive wheel to axle with 5/32 dia x 2" cotter pin. Install the free wheel on the opposite end of axle. Insert 5/32 dia x 1" cotter pin in the hole near the end of axle to retain free wheel.**

**3. Turn spreader upright and install end of handle tube with DOT between handle braces as shown. Secure with (2) 1/4-20 x 1 1/2" hex bolts and nuts.**

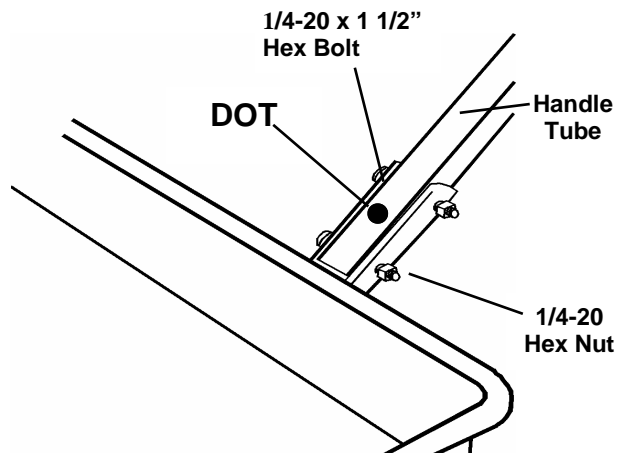

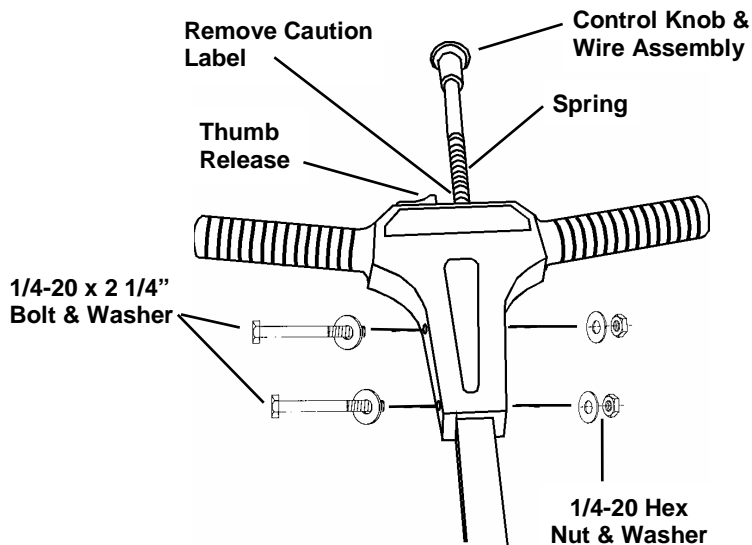

**4.** Feed control knob/wire through the T-handle until spring touches the round hole. **CAUTION: Do Not Compress Spring At This Time.** Feed wire through the square handle tube. **Be sure wire passes above the bolts in the handle brace.** Secure T-handle to the tube with (1) 1/4-20 x 2 1/4" hex bolts, (2) washers, and (1) hex nut in the holes. Remove caution label and push the thumb release toward the center and push down knob and shutoff spring until knob latches.

**CAUTION: Once knob is latched, do not move thumb release until you have completed in step #5.**

**5.** Slide wire retaining clip onto wire as shown. Insert wire through hole shutoff plate. Slide wire retaining clip over shutoff plate and wire until the clip locks into place.

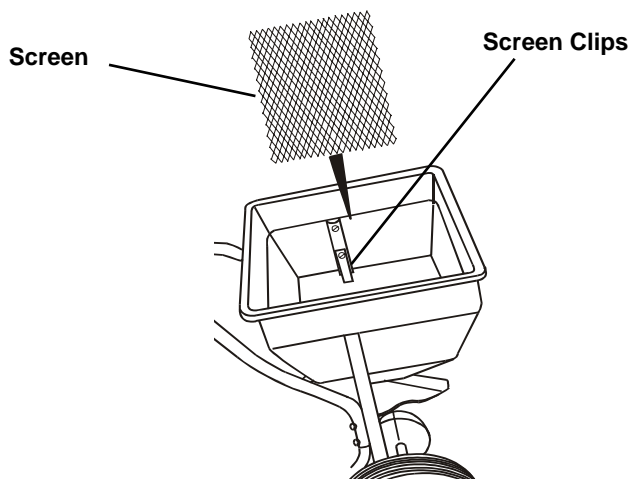
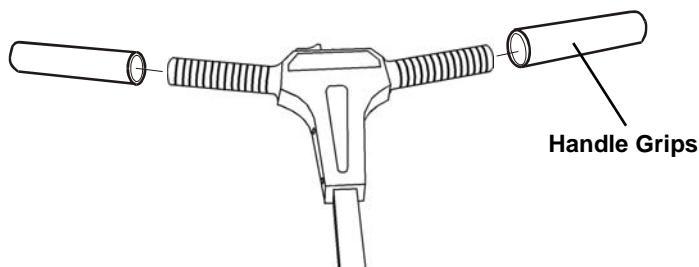
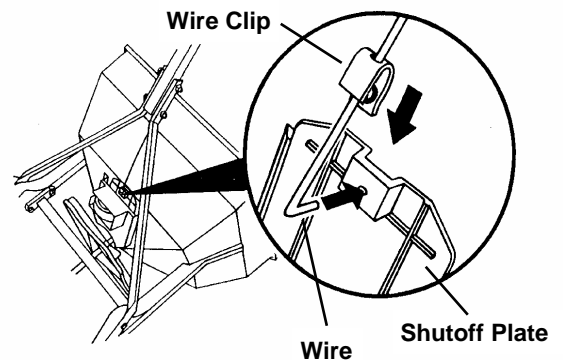

**6.** Install handle grips onto the handle as shown. Soapy water will ease installation. (Do not use petroleum based products). Insert screen into hopper by sliding it under the screen clips.

# OPERATION

**1.** Check the product package for the rate setting, and recommended swath width. Turn the spreader OFF by pushing the control knob in. Rotate the rate cam to the proper setting.

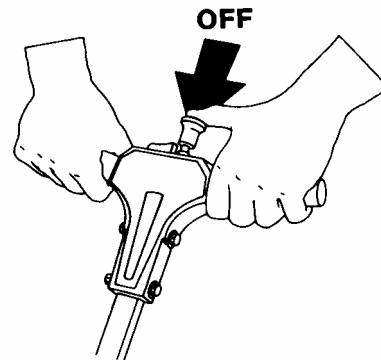

**2.** The rate setting is adjusted by rotating the rate cam to the desired setting. The rate cam locks at each setting.

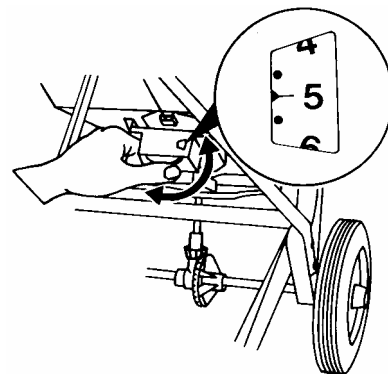

**3.** Always fill the spreader on the driveway or sidewalk-not on the lawn. Make sure spreader is in the "OFF" position. Empty after each use.

**4.** Start spreader moving, then open spreader by pushing the thumb release to the "ON" position. Always push spreader, never pull. Push knob down to close spreader.

**5.** Hold handle so top of spreader is level. Tipping the spreader too far can cause uneven spreading.

**6.** The settings and swath widths on the product label are recommended starting points. Always check the delivery rate and pattern on a small area before treating a large area. Actual delivery rate can vary due to weather conditions, operating variables, and condition of the product being applied. See "HOW TO DETERMINE SPREADER SETTING AND SWATH WIDTH" for details.

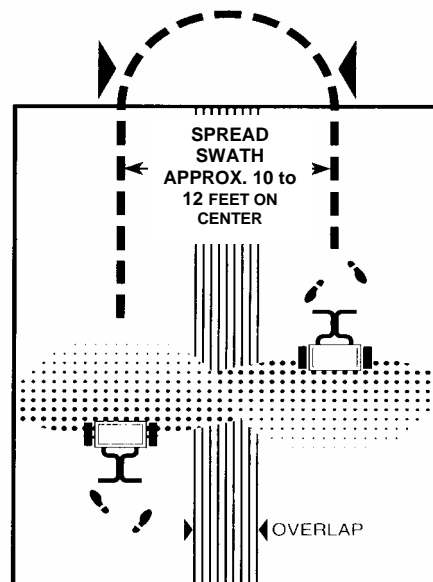

**7.** Push spreader 2 1/2 m.p.h. (18 feet in 5 seconds) for full 8' to 14' spread pattern when applying fertilizer products. Apply header strips at each end of area to be treated then space trips across the area as shown.

**8.** Empty spreader after each use. Return leftover material to its original container.

# HOW TO DETERMINE SPREADER SETTINGS AND SPREAD WIDTH

Two major factors should be considered when determining correct spreader settings of any product:

1. The product application rate, or the amount of material applied per 1,000 square feet.
2. The effective pattern width, or the actual width in which material is applied. Label settings are a guide and can be affected by numerous factors.

## EFFECTIVE PATTERN WIDTH

A simple visual pattern test can be made by operating the spreader over a non-turf area and evaluating the pattern. A more accurate method is to place a row of common, disposable, aluminum cake pans approximately 1 foot on centers. Set the rate cam at a middle setting and make 3 or 4 passes in the same direction as shown. Pour the material collected from each pan into individual bottles of the same size. Set them side by side in order, and visually inspect their volume. The effective pattern width is the distance out from the spreader to a point where the amount of material is 1/2 the average amount in the center pans. This distance is multiplied by 2 to achieve the total effective pattern width.

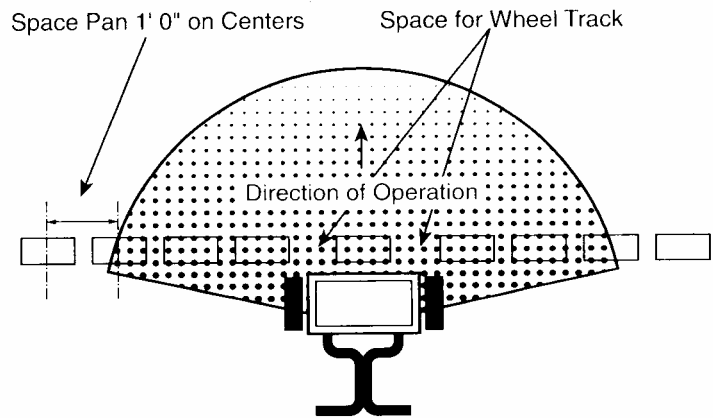

## APPLICATION RATE

Knowing the effective pattern width (for example, 10 feet), measure a distance equal to 100 square feet (10' x 10' area covered). Determine the product coverage is pounds/ 100 sq. ft. by taking the weight of the product and dividing it by the recommended square foot coverage (add two zeroes to the weight of the bag).

**EXAMPLE:** Product weight: 25 lbs.  
sq. ft. coverage: 5,000 sq. ft.  
2500 lbs. - 5,000 sq. ft.  
= .5 lbs. / 100 sq. ft.





Weigh out between 15 to 20 lbs. of material and spread over the 100 sq. ft. area. Weigh remaining material left in hopper and adjust rate setting as required. Repeat test until application rate is correct.

# RATE SETTING CONVERSION

The following provides approximate PrizeLAWN MPR I settings for those units listed.

PrizeLAWN MPR I Setting	2	3	4	5	6	7	8	9	10	11	12	13	14	15	16	17	18
PrizeLAWN BF-1 /SS,HVO, CBRIII, Setting	G	H	J	K	M	N	N1/ 2	O	P1/2	Q	R	S	T	U	V	X	Z
Lesco Hi-WHEEL Setting	E	F	G	H	I	J	K	L	—	—	M	N	O	—	P	R	S
Scott Speedy Green Setting	—	—	2	—	3	—	4	—	5	—	6	—	7	—	8	—	—
Scotts R8A/SR-1, AP&SR2000 Setting	I	J	L	M	O	P	—	Q	—	S	T	U	—	V	W	X	Z

The following provides approximate PrizeLAWN MPR I settings when only the product weight, square foot coverage, and visual inspection of the material is available.

FERTILIZER PARTICLE SIZE	BAG RATE Pounds of fertilizer used per 1,000 sq. ft. of coverage	APPROX. SETTING	APPROX. SPREAD WIDTH
Large, heavy particles 	5	6	12 FT.
	10	9	12 FT.
	15	11	12 FT.
Medium- mixed particles 	5	5	10 FT.
	10	7	10 FT.
	15	9	10 FT.
Small particles (nitrogen) 	1	2	10 FT.
	2	4	10 FT.
	3	5	10 FT.
Mixed size particles -some fines 	5	6	8 FT.
	10	9	8 FT.
	15	11	8 FT.
Light weight particles 	5	4	6 FT.
	10	5	To
	15	6	8 FT.

The conversions should be used as guidelines for establishing proper rate settings for the particular product being applied. Steps for obtaining the most accurate settings are outlined in the "How to Determine Spreader Settings and Spread Width" section of this manual.

These settings are approximate and may vary due to physical characteristics of the product. Walking speed, wear, condition of the turf and humidity, may cause actual rate setting to deviate. No expressed nor implied warranty or guarantee is provided as to coverage or uniformity indicated by these rate settings.

# MAINTENANCE

1. Never store unused material in spreader. Return unused product to its original container.

2. Wash spreader thoroughly after each use and dry completely in sun or heated area.

3. Oil the axle bearings, impeller shaft bearing in hopper, control knob in T-handle.

4. Remove gear cover and wash gears thoroughly. Oil all bearing areas and face of gear teeth. Re-install gear cover.

5. Gear mesh should be checked on a regular basis during high use periods. Clearance between the axle gear and pinion gear should be minimal but not tight. If adjustment is necessary, loosen axle collar set screw and hold gears together. Slide axle collar against the gear support and tighten axle collar set screw. Spin drive wheel. Gears should run freely and smoothly.

6. Impeller surface should be cleaned periodically to remove build-up of product. Build-up can cause the spread pattern to change.

7. Tire pressure should be 20-25 PSI.

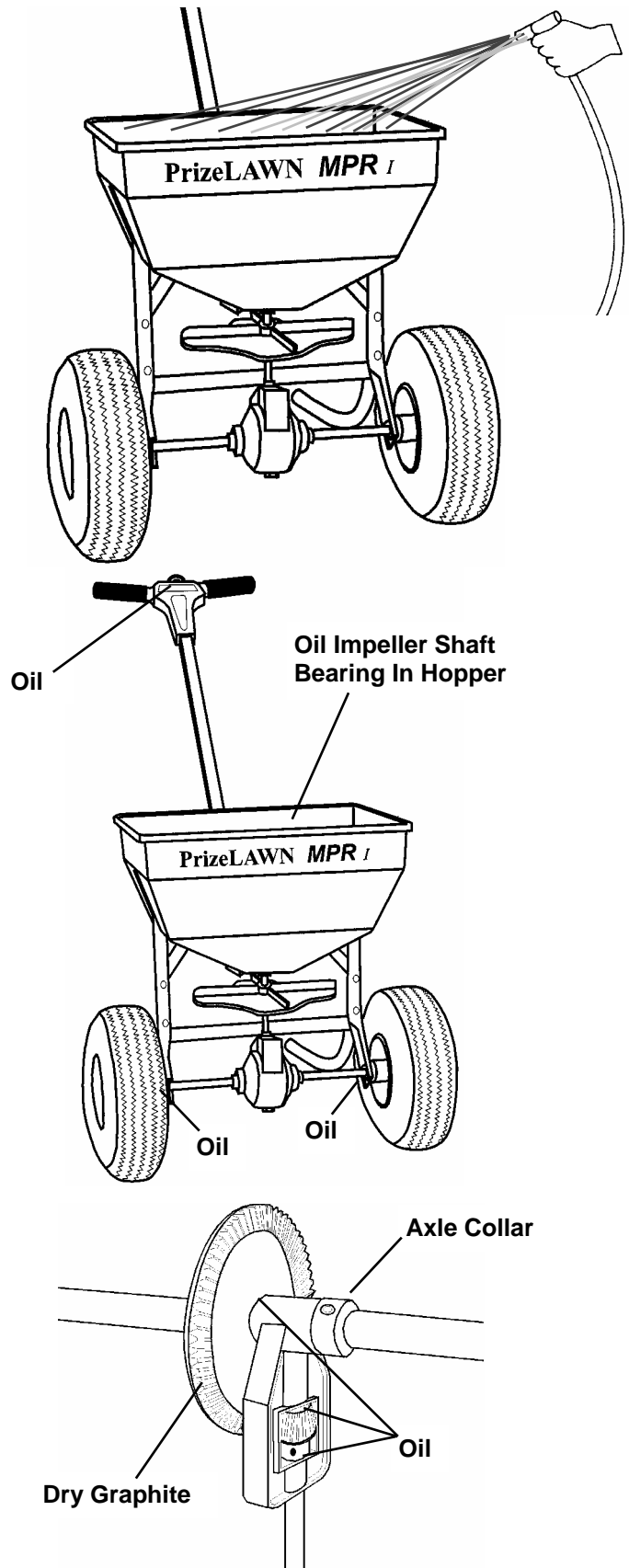

# Parts List for Model *MPR 1*

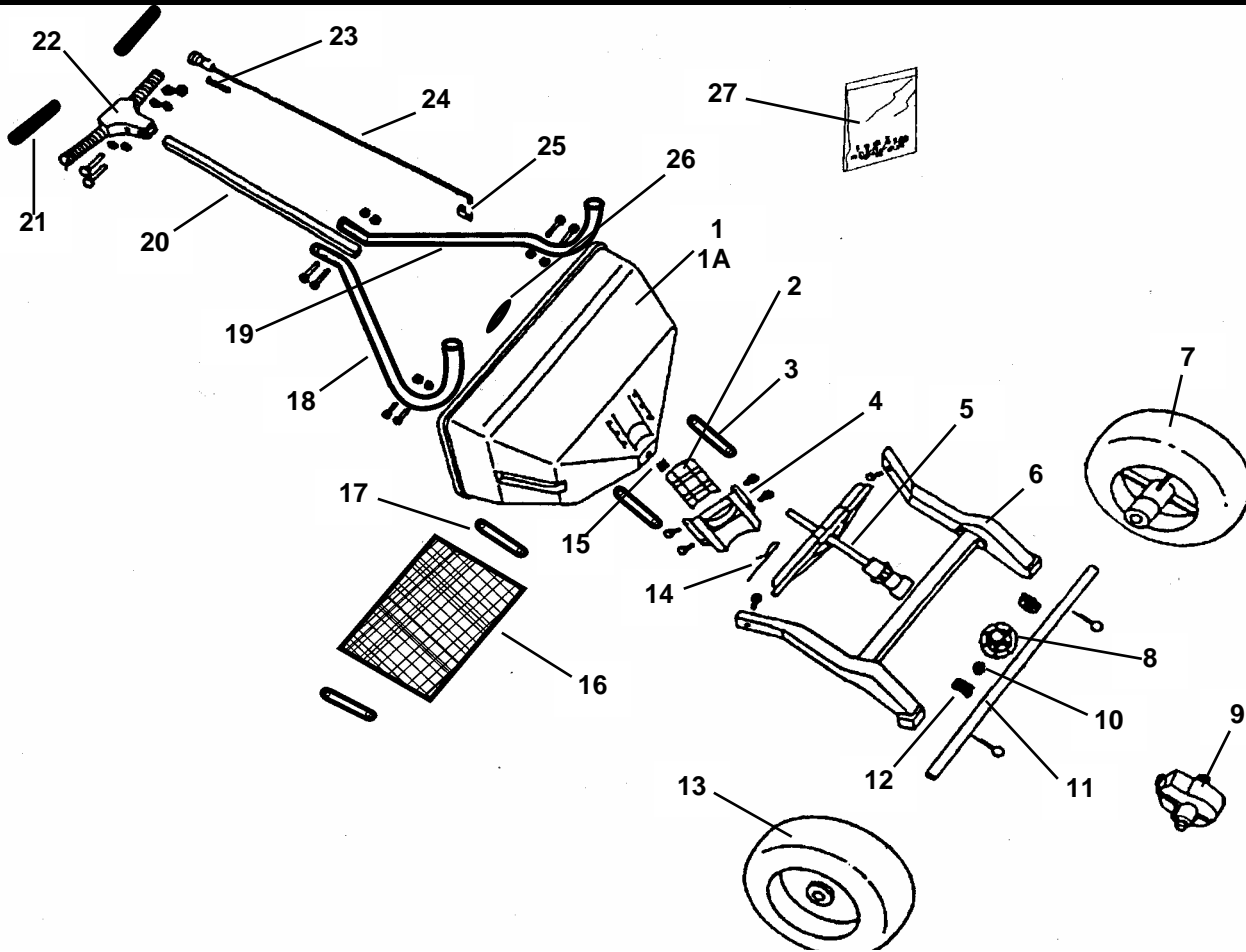

PART OF OUR SERVICE IS PROVIDING REPLACEMENT PARTS. Parts may be obtained through your local distributor. be sure to give:

1. SPREADER MODEL NUMBER
2. SPREADER NAME
3. PART NUMBER
4. NAME OF PART AS SHOWN

IF YOUR LOCAL DISTRIBUTOR CANNOT SUPPLY PARTS, CONTACT:



## PSB Company

555 West Goodale Street

P.O. Box 1089

Columbus, Ohio 43216-1089

(614) 228-5781 EXT. 655

FAX (614) 221-9398

[www.PSBCompany.com](http://www.PSBCompany.com)

Key No.	Description	Part No.	Key No.	Description	Part No.
1	Hopper Assembly	15269	14	Agitator	14510
1A	Hopper *	15270	15	Impeller Shaft Bearing *	14312-1
2	Shutoff Plate *	14454-1	16	Hopper Screen	14603-1
3	Shutoff Plate Guides (2) *	15272	17	Screen Clips (2)	14022
4	Rate Cam & Chute Assembly *	14455-1	18	Handle Brace W/ Plug- LH.	15258
5	Impeller Assembly	15263	19	Handle Brace W/ Plug- RH.	15261
6	Frame Assembly	15262	20	Handle Tube	15283-1
7	Drive Wheel	14939-1	21	Handle Grips (2)	15264
8	Axle Gear	13360	22	T-Handle Assembly	13634-2
9	Gear Cover Assembly	14629	23	Control Knob Spring	14462
10	Axle Collar	13362	24	Control Knob & Wire Ass'y.	13640-2
11	Axle	15276	25	Wire Retaining Clip	13643-1
12	Axle Bushings (2)	14951	26	Hopper Plug	15271
13	Free Wheel	14940-1	27	Parts Package	15273